

This document and its contents are the property of GrillSymbol Oü and must not be copied, reproduced or disclosed to any third party without prior written permission. Contravention will be prosecuted.

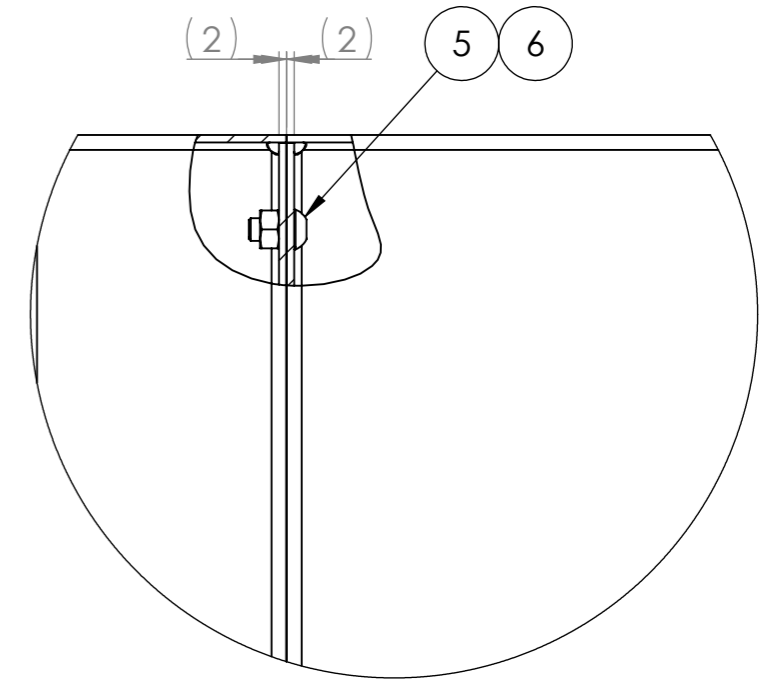
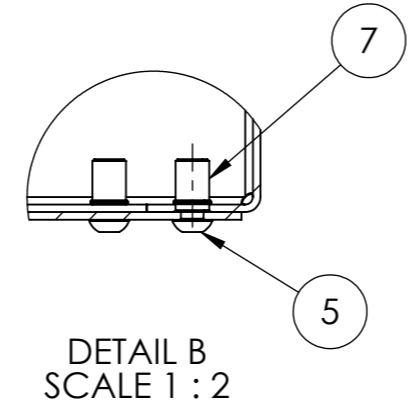
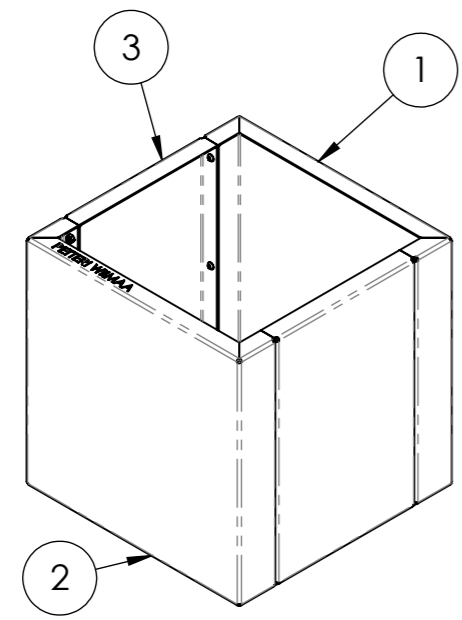
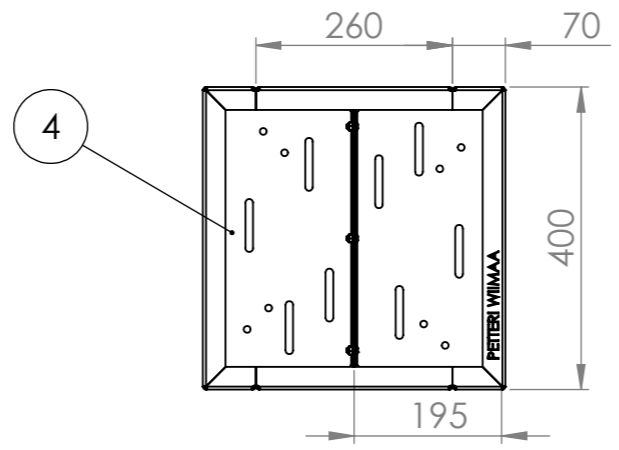
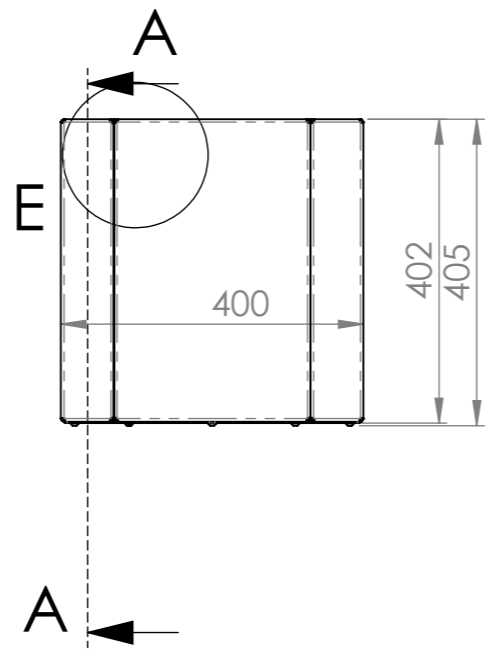
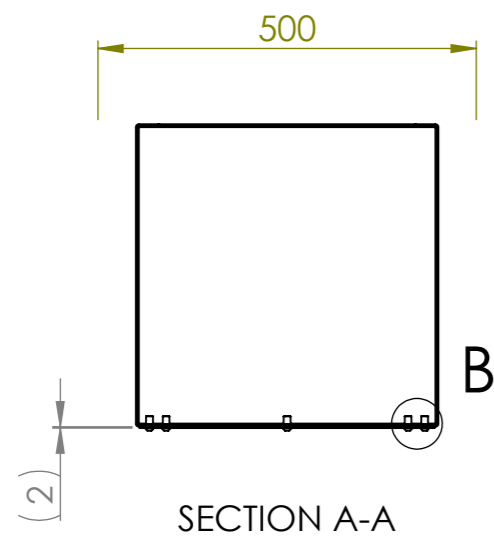

Revision			
Rev.	Description	Date	Approver
A	Revised 11.654	03.10.2023	RK

ITEM NO.	PART NUMBER	Rev.	DESCRIPTION	TYPE	MATERIAL	QTY
1	11.631		Corner L	PLT 2 - 453x587	Cor-Ten	1
2	11.631-G		Corner L	PLT 2 - 453x587	Cor-Ten	1
3	11.633		Wall M	PLT 2 - 313x453	Cor-Ten	2
4	11.634		Bottom Plate M	Plate 2 - 390 x 210	Cor-Ten	2
5	M8x12 DIN 7380		Bolt	M8x12 DIN 7380 zn	8.8	32
6	M6 DIN 934		Nut	M6 DIN 934	8	15
7	Tension nut		Blind rivet nuts	MFx 23-CO ZP M 6 x 16	8	12

Drw: R.Kiveste 17.11.2023		Type:		General tolerance symbols acc.ISO2768-mK	
Chk: R.Kiveste 17.11.2023		Material:		Welding tolerances EVS-EN ISO 13920 - B	
App:		Project: Flower Pot		Quality level weld EVS-EN ISO 5817 - C	
Sheet: 1/4		Size: A3		Thermal cutting ISO 9013	
Scale: 1:10		Weight kg: 14.9		Description: Clara M	
Metric: mm		Metric: mm		Drawing number: 11.630	
		GrillSymbol Oü Suur-Sõjamäe 19A 11415 Tallinn, Estonia Phone: +372 6 827 212		Rev:	