

This document and its contents are the property of GrillSymbol Oü and must not be copied, reproduced or disclosed to any third party without prior written permission. Contravention will be prosecuted.

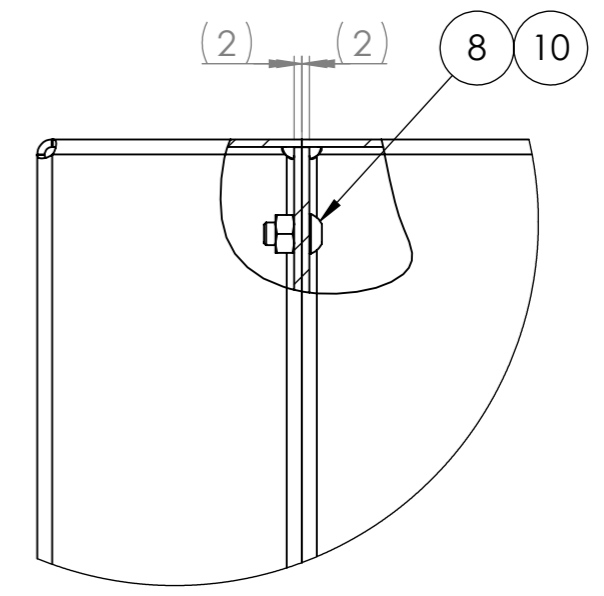
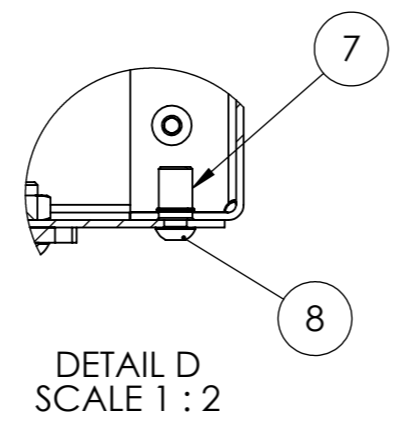
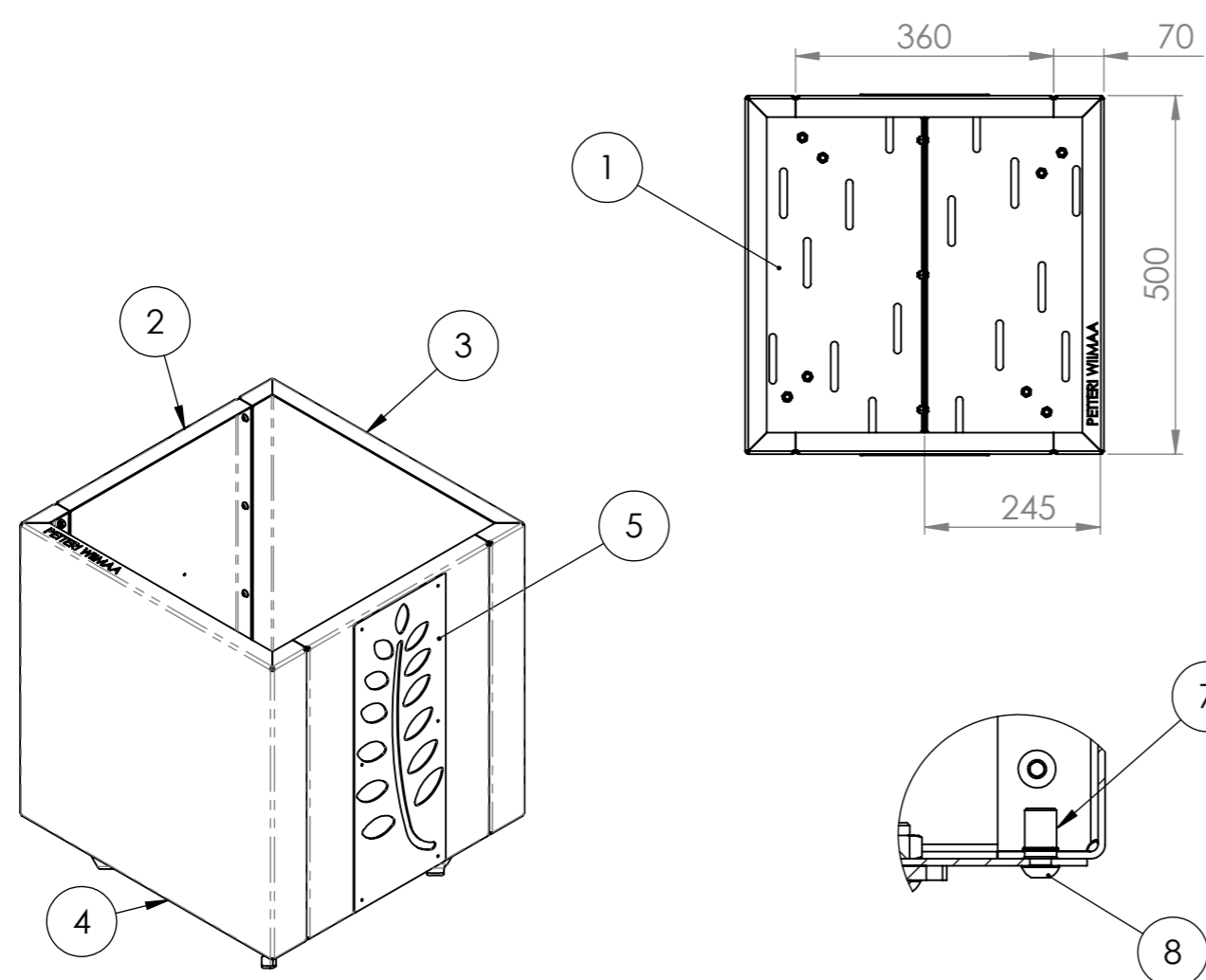
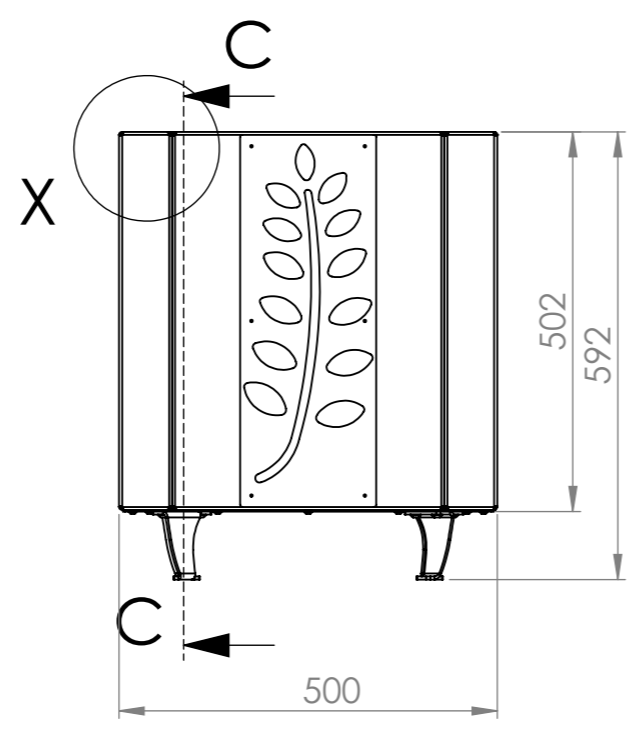
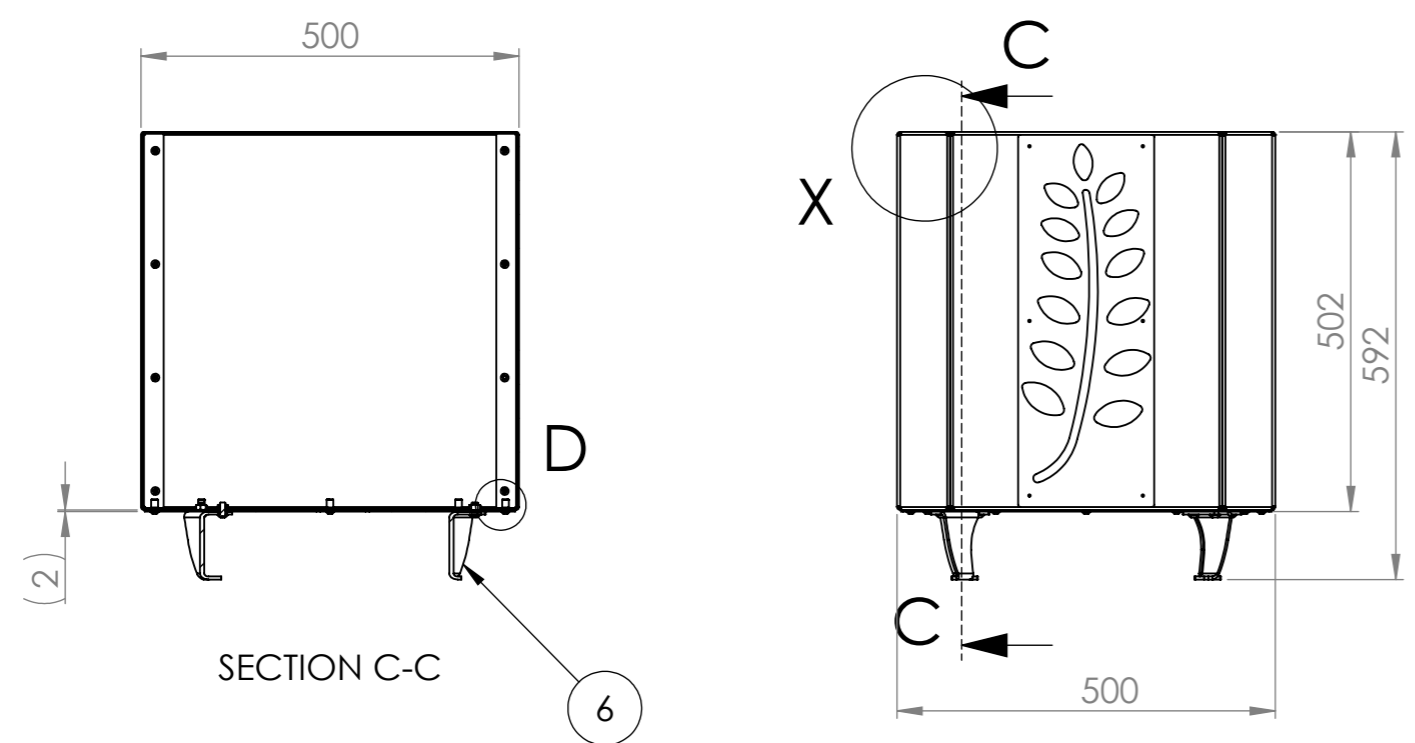

DETAIL X  
SCALE 1 : 2

Revision			
Rev.	Description	Date	Approver

ITEM NO.	PART NUMBER	Rev.	DESCRIPTION	TYPE	MATERIAL	QTY.
1	11.644		Bottom Plate L	Plate 2 - 490 x 260	Cor-Ten	2
2	11.643-G		Wall L	PLT 2 - 413x553	Cor-Ten	2
3	11.641		Corner L	PLT 2 - 553x687	Cor-Ten	1
4	11.641-G		Corner L	PLT 2 - 553x687	Cor-Ten	1
5	11.225	C	Ballerina L Leaf	Leht 2 - 492x180	Cor-Ten	1
6	11.044		Leg	Leht 4 - 126,8x65,2	Cor-Ten	4
7	Tension nut		Blind rivet nuts	MFx 23-CO ZP M 6 x 16	EN 10294-1 E470	16
8	M8x12 DIN 7380		Bolt	M8x12 DIN 7380 zn	8.8	35
9	M6x12 DIN 7380		Bolt	M6x12 DIN 7380 zn	8.8	8
10	M6 DIN 934		Nut	M6 DIN 934	8	19
11	M8 DIN 934		Nut	M8 fzb DIN 934	8	8

Drw: R.Kiveste 17.11.2023 Chk: R.Kiveste 17.11.2023 App:		Type:		General tolerance symbols acc.ISO2768-mK Welding tolerances EVS-EN ISO 13920 - B Quality level weld EVS-EN ISO 5817 - C Thermal cutting ISO 9013	
Sheet: 2/4 Scale: 1:10		Size: A3 Weight kg: 25.4 Metric: mm		Project: <b>Flower Pot</b> Description: <b>Fat Ballerina-L</b>	
Scale: 1:10 Weight kg: 25.4 Metric: mm			GrillSymbol Oü Suur-Sõjamäe 19A 11415 Tallinn, Estonia Phone: +372 6 827 212		Drawing number: <b>11.640-G</b>