

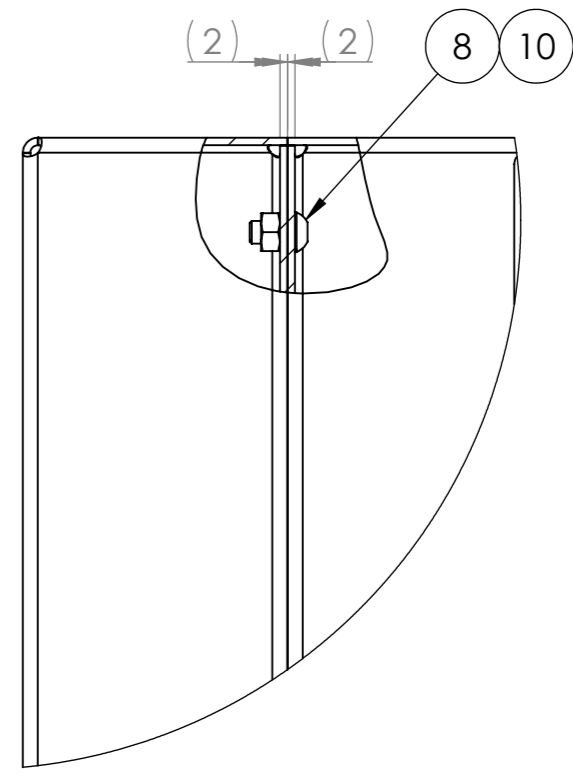

This document and its contents are the property of GrillSymbol Oü and must not be copied, reproduced or disclosed to any third party without prior written permission. Contravention will be prosecuted.

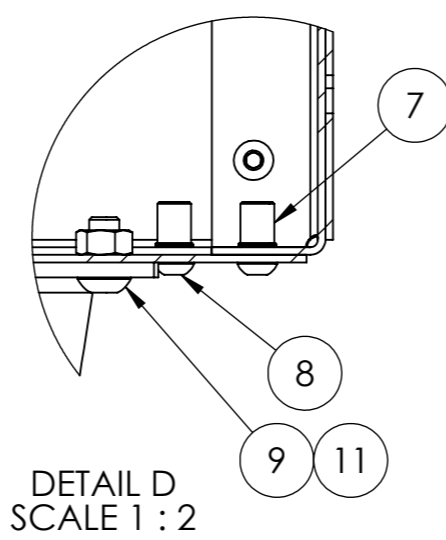
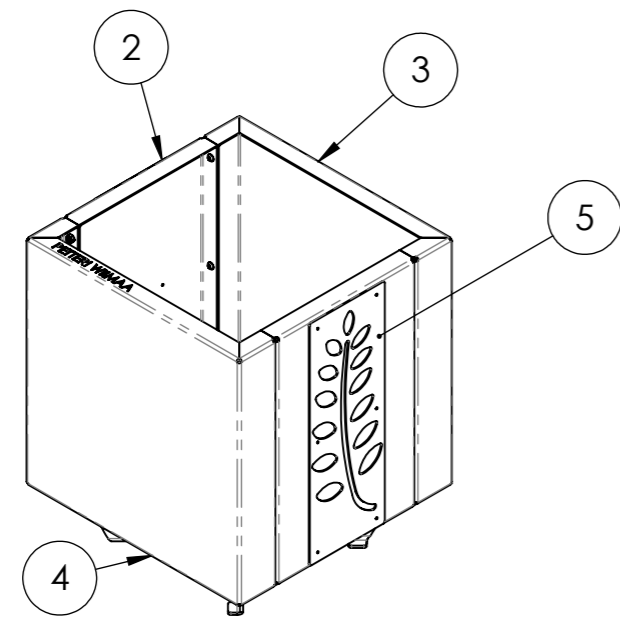
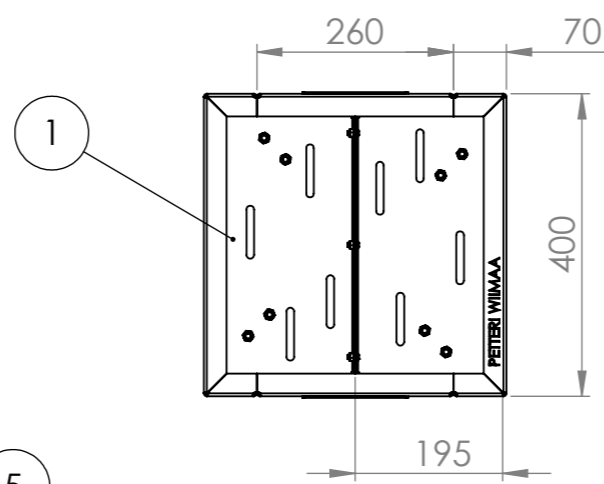
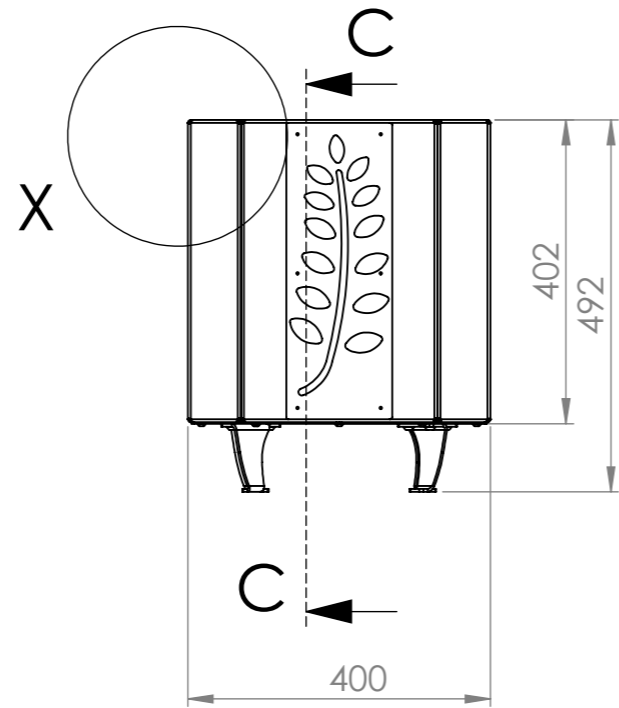
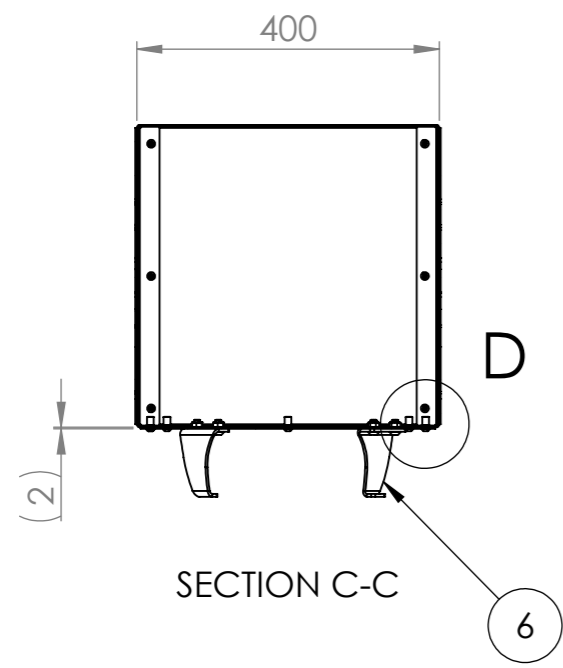

DETAIL X
SCALE 1 : 2

Revision			
Rev.	Description	Date	Approver

ITEM NO.	PART NUMBER	Rev.	DESCRIPTION	TYPE	MATERIAL	QTY.
1	11.634		Bottom Plate M	Plate 2 - 390 x 210	Cor-Ten	2
2	11.633-G		Wall M	PLT 2 - 313x453	Cor-Ten	2
3	11.631		Corner L	PLT 2 - 453x587	Cor-Ten	1
4	11.631-G		Corner L	PLT 2 - 453x587	Cor-Ten	1
5	11.215	C	Ballerina M Leaf	Plt 2 - 392x140	Cor-Ten	1
6	11.044		Leg	Leht 4 - 126,8x65,2	Cor-Ten	4
7	Tension nut		Blind rivet nuts	MFx 23-CO ZP M 6 x 16	EN 10294-1 E470	12
8	M8x12 DIN 7380		Bolt	M8x12 DIN 7380 zn	8.8	28
9	M6x12 DIN 7380		Bolt	M6x12 DIN 7380 zn	8.8	8
10	M6 DIN 934		Nut	M6 DIN 934	8	15
11	M8 DIN 934		Nut	M8 fzb DIN 934	8	8

Drw: R.Kiveste 17.11.2023	Type:	General tolerance symbols acc.ISO2768-mK Welding tolerances EVS-EN ISO 13920 - B Quality level weld EVS-EN ISO 5817 - C Thermal cutting ISO 9013
Chk: R.Kiveste 17.11.2023	Material:	
App:	Project: Flower Pot	Description: Fat Ballerina-M
Sheet: 2/4	Size: A3	Drawing number: 11.630-G
Scale: 1:10	Weight kg: 17.0	
Metric: mm	 GrillSymbol Oü Suur-Sõjamäe 19A 11415 Tallinn, Estonia Phone: +372 6 827 212	