

1

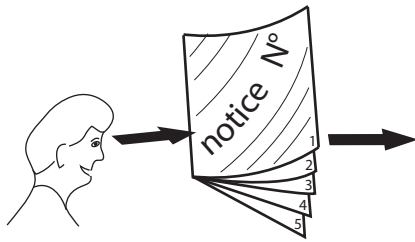

- 1) N°NOT066
- 2) N°NOT610
- 3) N°NOT461
- 4) N°NOT465
- 5) N°NOT468
- 6) N°NOT473



PROCTITY[®]

N° OF :
.....

FRANCE: +33.(0)2.54.80.32.99
EXPORT: +33.(0)1.39.08.26.55

Station-bus Oléron - 2520 x 1560 - Réf. 529308

Poteaux 80 x 80, 1 bardage de fond et 1 bardage latéral (à droite ou à gauche)

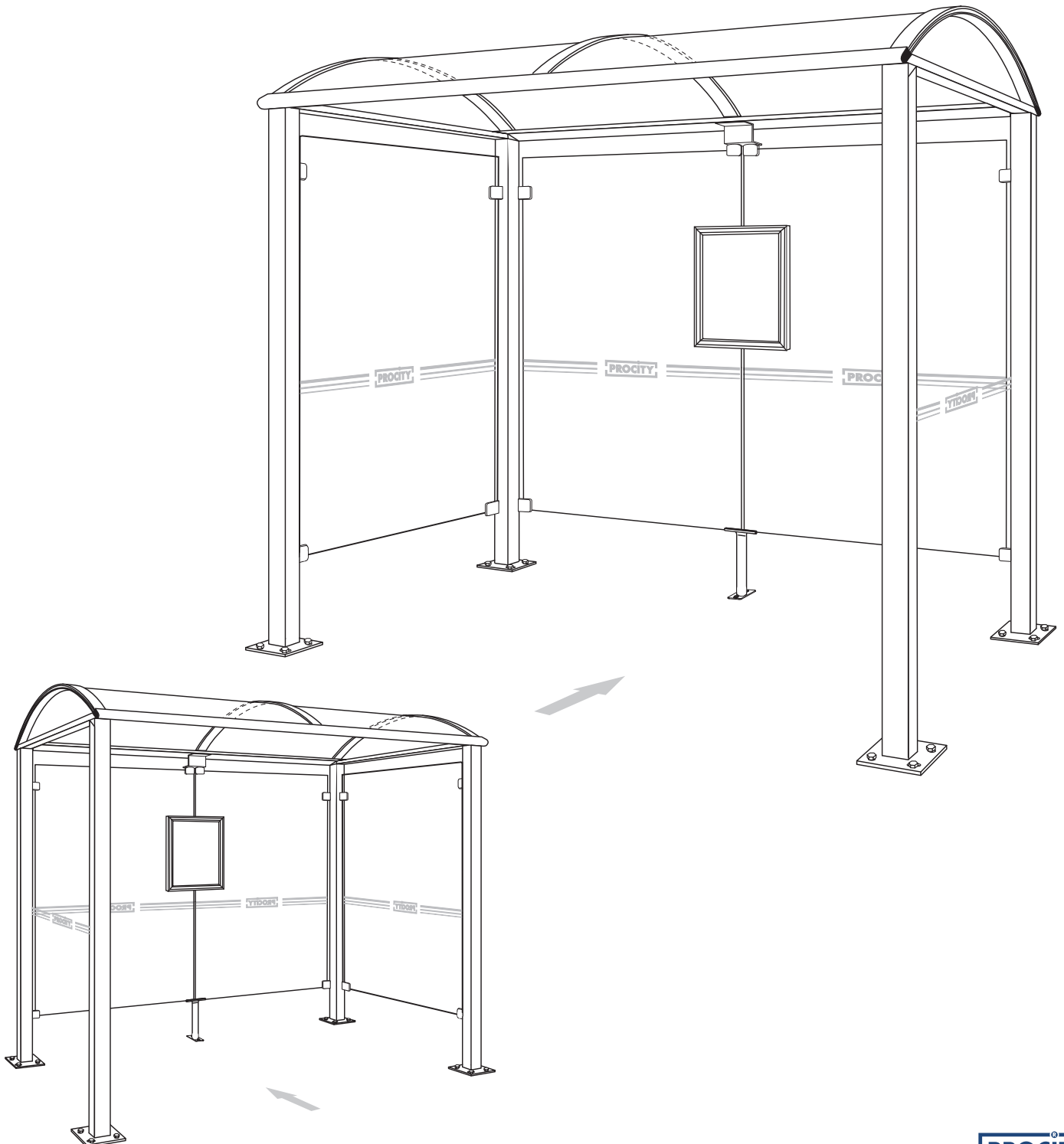

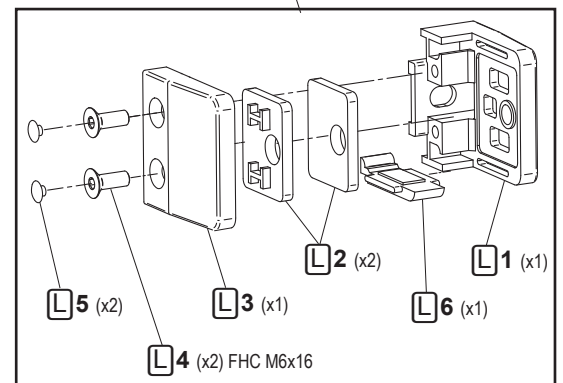
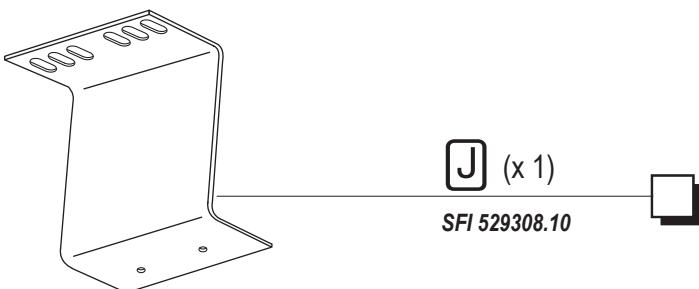
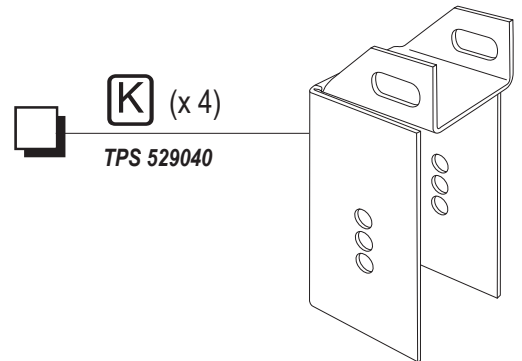
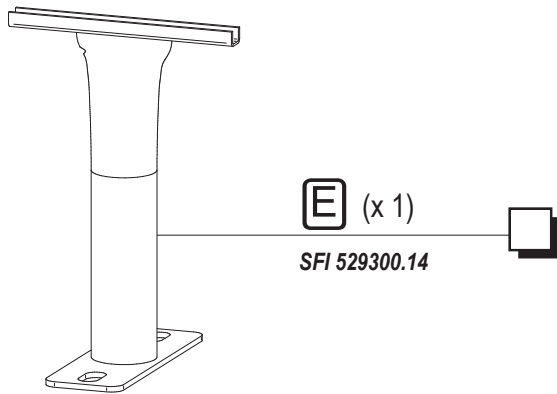
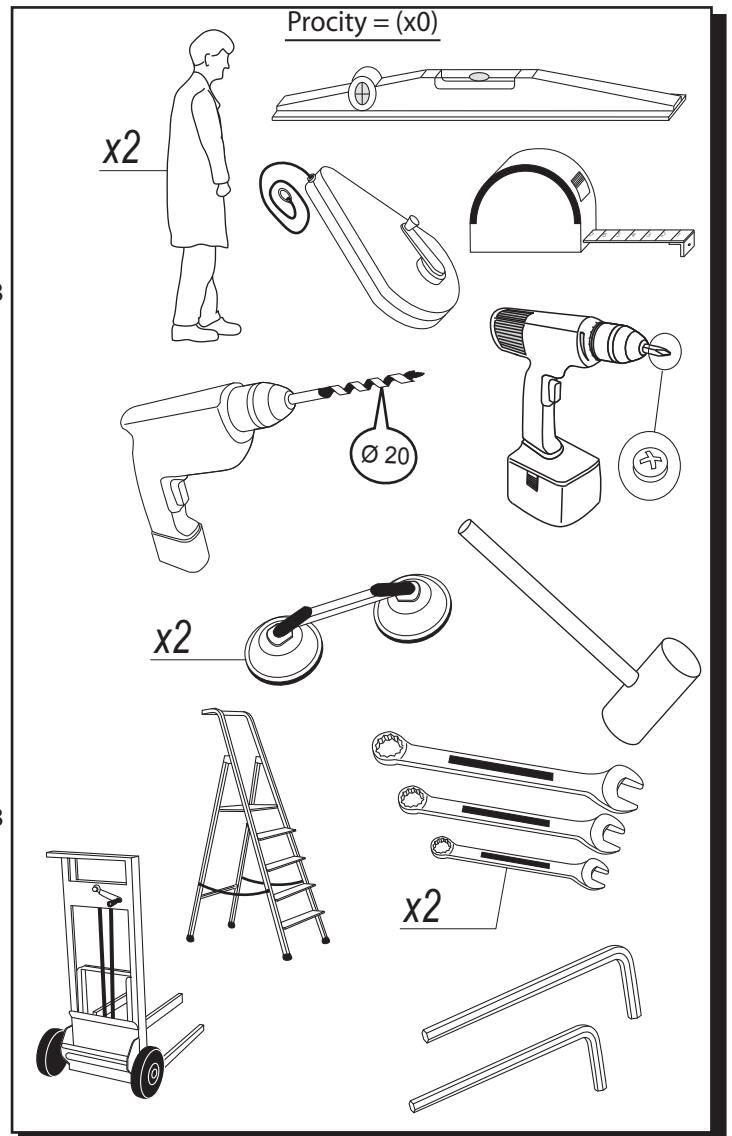
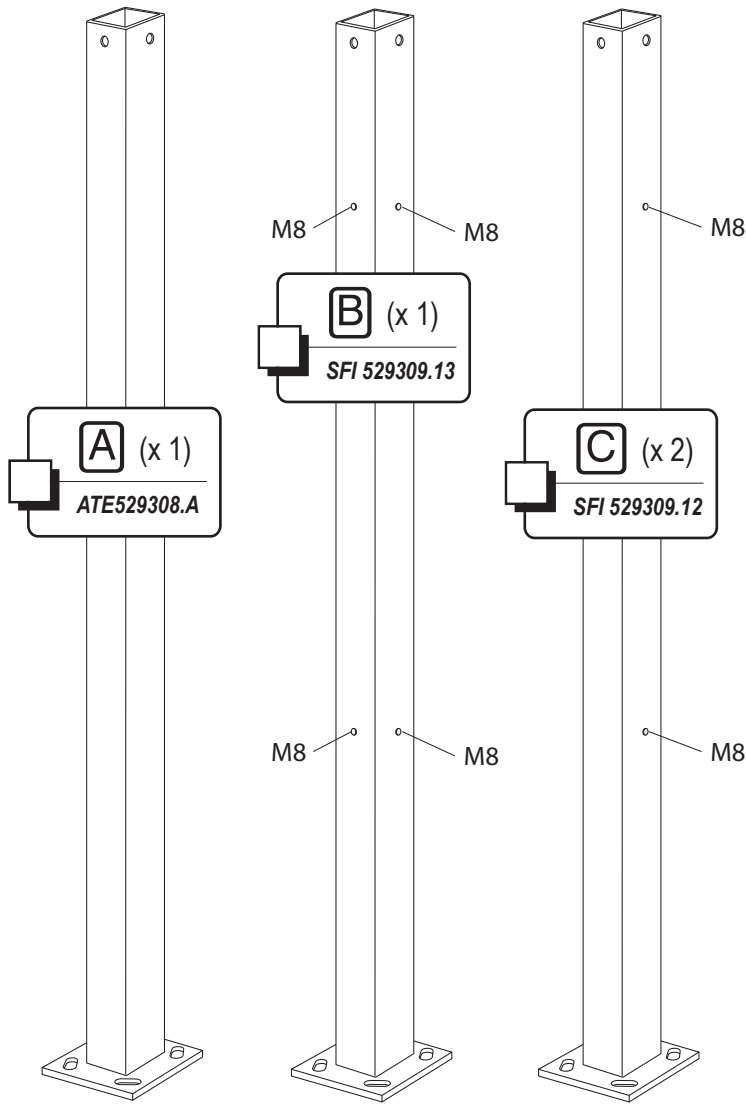

Y1 (x 4)
ATE 529210



(x 1)
505045 → **N° NOT473**

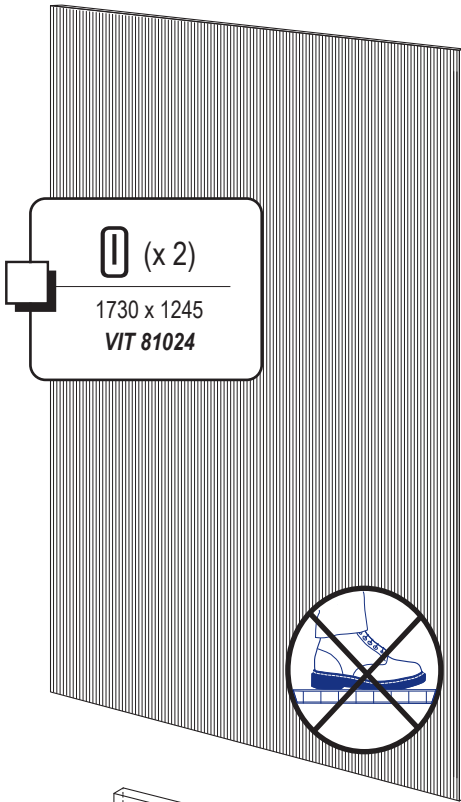
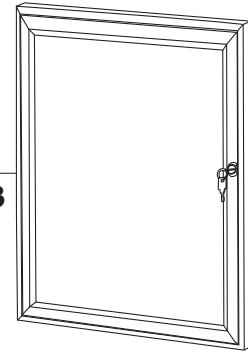

I (x 2)
1730 x 1245
VIT 81024



M (x 2)
2500
529300.G

Y (x 2)
2500
529040.01

F1 (x 3)
529300.E

F2 (x 3)
529300.D

H (x 2)
60x40x1600
529300.F

O (x 2)
1860 x 1154
VIT 81123.02

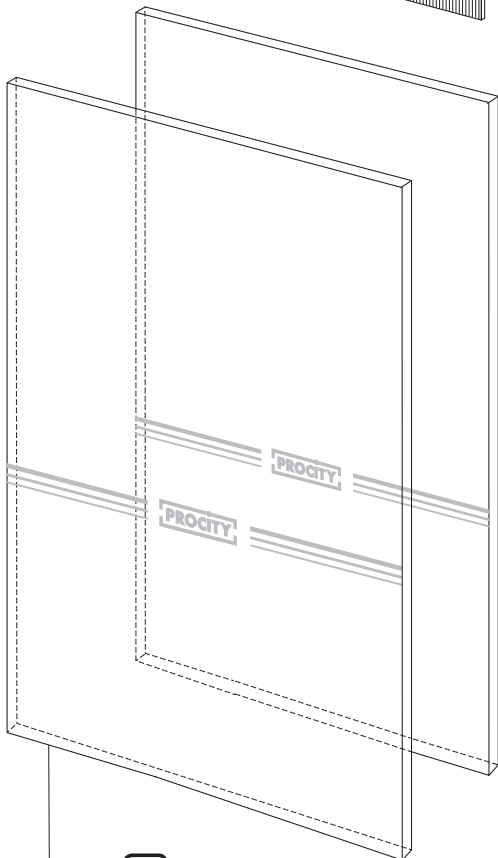

P (x 1)
1860 x 1355
VIT 81125.02

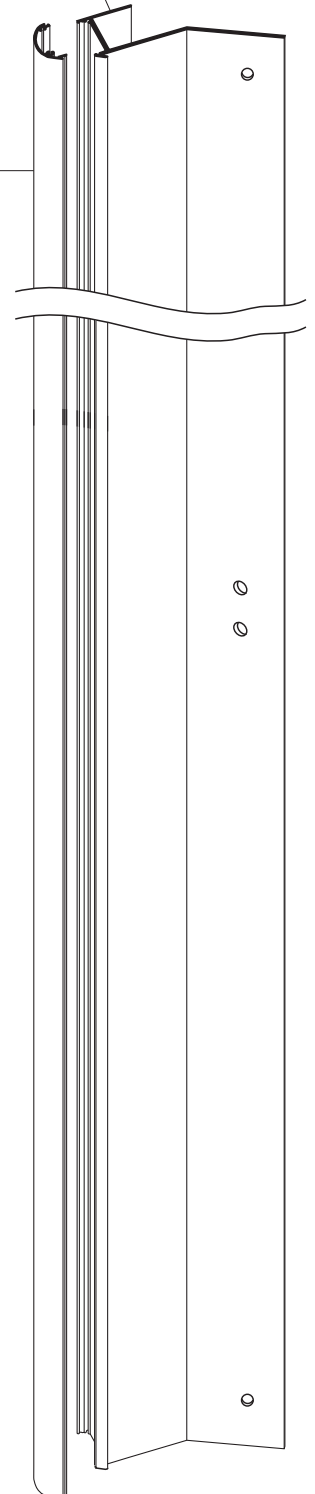

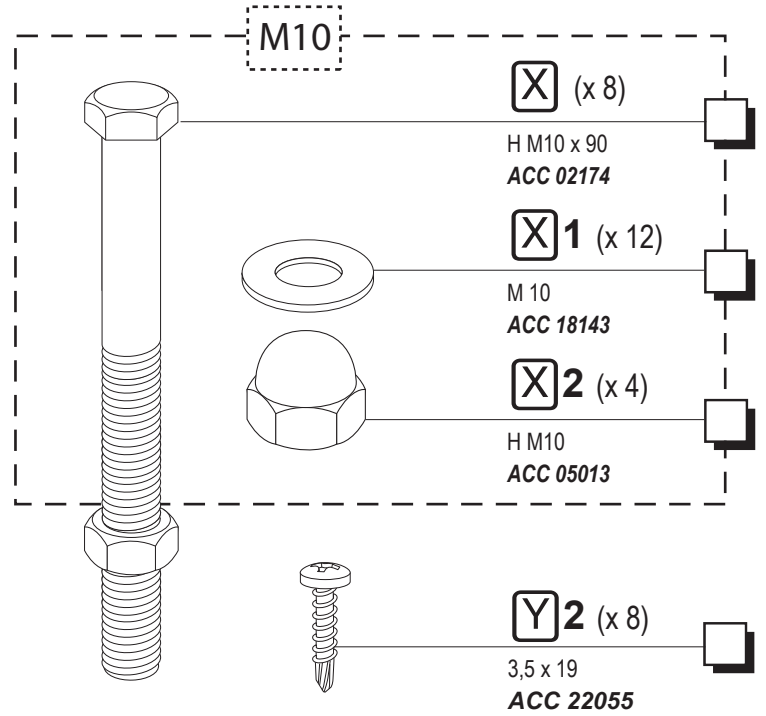
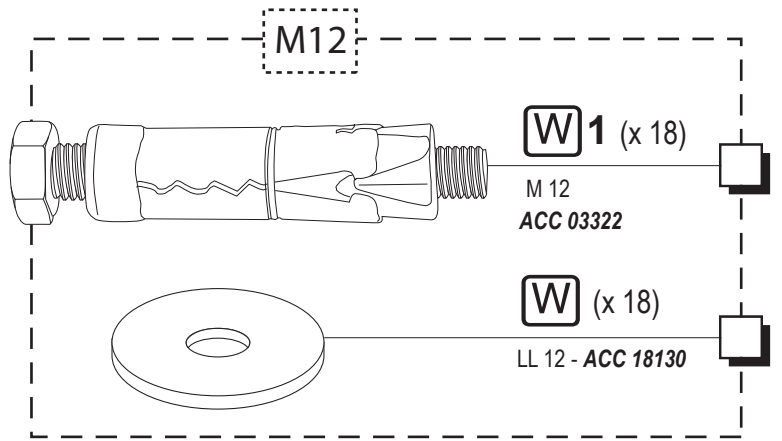
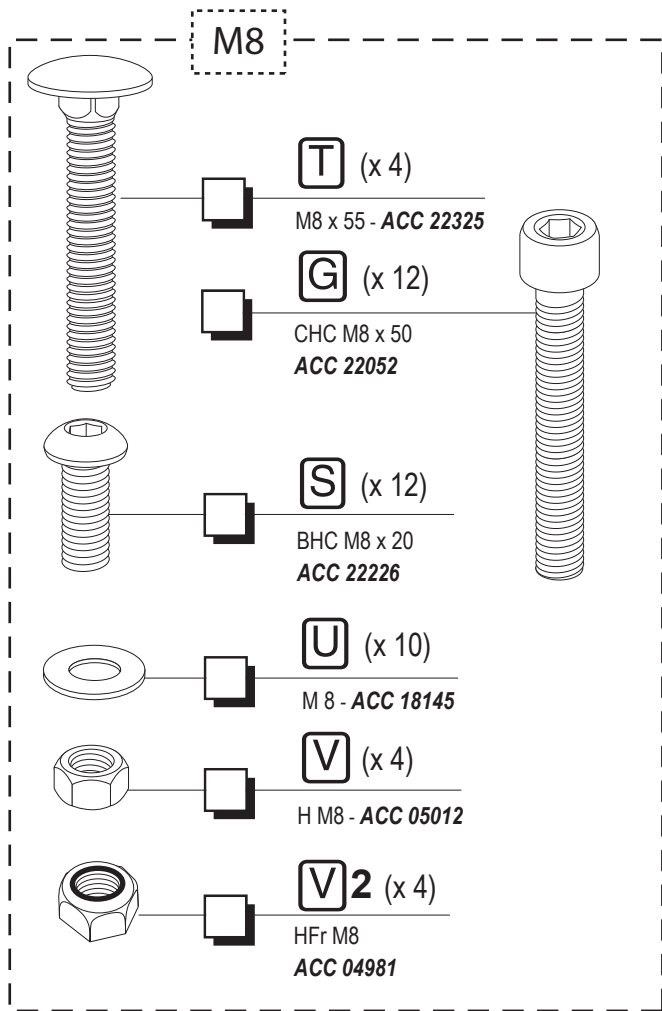

1

