

**SLIMCASE WALL MOUNTED**

Digital Displays | Tablet Holders



**SLIMCASE WALL MOUNTED**

• Tablet holder for models Apple iPad 10.2" (2019) and Samsung Galaxy Tab 10.1" (2019) • Ready to mount – pre-drilled holes for screw fixing • Speaker and volume control accessible from the edge

**SLIMCASE WALL MOUNTED**

• Tablet-Halter für Apple iPad Modelle 10.2" (2019) und Samsung Galaxy Tab 10.1" (2019) • Installationsbereit - Vorbohrungen für Schraubbefestigung • Lautsprecher und Lautstärkereger zugänglich von der Seite

**SLIMCASE WALL MOUNTED**

Digital Displays | Tablet Holders

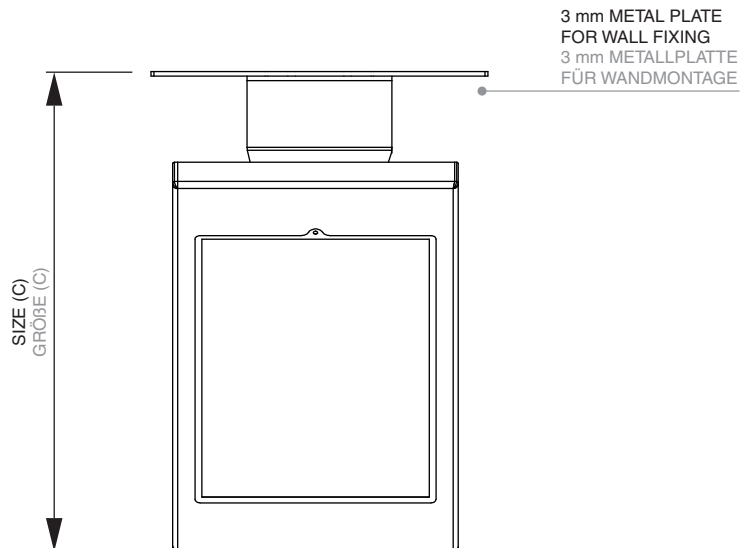
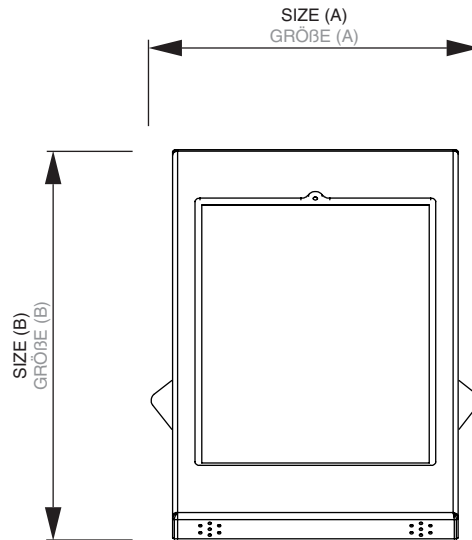
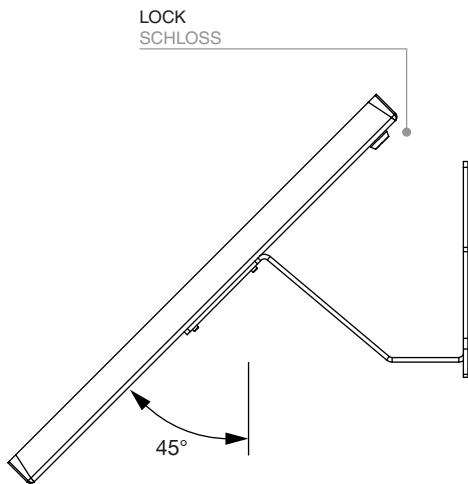

## SLIMCASE WALL MOUNTED

Digital Displays | Tablet Holders



Article code	EAN / GTIN	Tablet type / size	Size (A x B x C)	Net weight
Artikelcode	EAN / GTIN	Tablet Typ / Zoll	Größe (A x B x C)	Netto Gewicht
DTSA20WC9003	8596052122088	Apple iPad / 10,2"	225 x 280 x 255 mm	2,30 kg
DTSS20WC9003	8596052122071	Samsung Galaxy Tab / 10,1"	225 x 270 x 245 mm	2,30 kg

Article code	Packing size	Packing weight	Pcs / Pallet	Weight of pallet	Volumetric weight	UPS ratio (Belt size)	Shipping
Artikelcode	Verpackungsgröße	Versandgewicht	Stck / Palette	Paletten-gewicht	Volumen-gewicht	UPS Koeffizient (Gurtmaß)	Versandart
DTSA20WC9003	262 x 312 x 247 mm	2,65 kg	88	254 kg	4,04 kg	1330 mm	UPS
DTSS20WC9003	262 x 312 x 247 mm	2,65 kg	88	254 kg	4,04 kg	1330 mm	UPS